

FLUORIDE ION MONITOR

FBM-100B (Panel type)

Continuously and rapidly measures the concentration of free fluoride ions contained in sample water. It can be used to control wastewater treatment processes in plants using hydrogen fluoride, such as semiconductor factories, or to monitor discharged water.

This instrument is panel-mounted, with immersion-type and flow-through-type detectors available, and a water jet cleaner is also provided.

Unlike the JIS K 0102 factory wastewater test method, this simplified method may be affected by the properties, pH, temperature, and components of the sample water. For details, please refer to the sample water conditions on the next page.

If the sample water conditions are not met, such as for coexisting components, we recommend using the “Fluoride Ion Measurement System (FMS-4)” which adds an ion strength adjustment agent to meet those conditions.



Features

- Rapid Response: For samples with low impurities, concentrations around 2 mg/L can be detected in approximately 60 seconds (90% response).
- The standard measurement range can be specified from three ranges: low, medium, and high (0 to 20, 200, and 2000 mg/L).
- 4-point alarm: In addition to upper and lower concentration limits, it can output contacts for conditions such as instrument malfunction, cleaning in progress, and maintenance in progress. Concentration alarms allow arbitrary setting of sensitivity range and delay time.
- Cleaner Control Output: Outputs AC 100V power to periodically operate the water jet cleaner (optional).
- The display has a backlight.
- We have obtained CE Marking.

Diagram

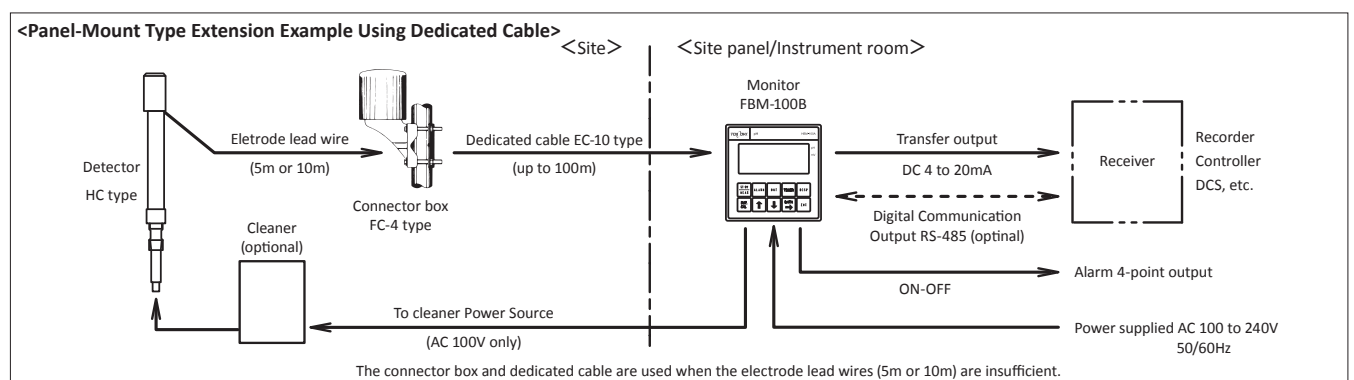

Standard specification

Model : FBM-100B (Panel mounting)
 Measurement method : Fluoride ion electrode method
 Display : Digital LCD display (with LED backlight)
 Measurement ranges : 0.0 to 99.9mg/L or 0 to 999mg/L or 0 to 9990mg/L
 Transmission output : DC 4 to 20mA Input/Output Ground-Isolated Type Load Resistance...650Ω or less
 Measurement (Transmission Output) Range : Arbitrarily set to 1/10FS width or more within the respective display ranges above
 Shipmet; Set to 0.0 to 20.0mg/L
 Set to 0 to 200mg/L
 Set to 0 to 2000mg/L
 Water temperature measurement range : 0 to 50°C
 Alarm function :
 Output ...4 circuits; ALARM 1 to 4 make contacts (a to contact)
 Contact capacity ...AC 250V 3A (resistive load) or DC 30V 3A (resistive load)
 Functions ...Selectable from Upper/Lower Limit Alarms, Cleaning in Progress, Maintenance in Progress, Instrument Malfunction For Upper/Lower Limit Alarms, Bandwidth and Action Delay Time are configurable
 Digital Output (Optional) : RS-485 (isolated), Modbus (RTU)
 External reading of measured values, setpoints, and other data, as well as issuing cleaning commands, is possible.
 Cleaner Control Output : Water jet cleaner driven by internal timer
 Periodically supply power (AC 100V, 2A or less).
 Cleaning cycle...0.1 to 48.0hours, variable
 Cleaning time...0.1 to 9.9minutes, variable
 Post to cleaning standby time...0.0 to 99.9 minutes, variable
 Temperature Compensation : Corrects the electromotive force of the fluoride ion electrode using the Nernst equation within a sample water temperature range of 0 to 40°C
 Performance (using calibration solution) : Linearity...Within±8% FS (excluding detector)
 Repeatability...While actual measurements using electrode combinations may vary due to sample water conditions, repeatability is approximately±30%.
 90% response time...Within 15seconds (excluding detector) Within 60seconds (including detector combination)
 Self to diagnosis : Calibration error...Displaying E-00 to 05
 Temperature sensor malfunction... Displaying E-12
 Memory error... Displaying E-20/21
 Burnout, or outputting abnormal signals
 Power supply voltage : AC 100 to 240V±10% 50/60Hz
 Power consumption : Approx. 9VA (at AC 100V),
 Approx. 14VA (at AC 240V)

Mounting method : Panel mount type
 Panel cut dimensions: 92mm × 92mm
 External dimensions : 96mm × 96mm × 90mm (W × H × D)
 Case structure : Indoor installation (IP30)
 Material and Finish : Body; Aluminum; Display Panel; Polyester Resin
 Aluminum Base Color; Display Panel; Light Yellow
 Ambient temperature and humidity : -10 to 50°C, 90% RH or less (no condensation)
 Weight : Approximately 0.6kg
 Water temperature : None
 output DC 4 to 20mA

Sampling water condition

pH : Stable pH range of 4 to 9... Note 1
 Temperature : Stable performance within a temperature range of 0 to 40°C...Note 2
 Electrical conductivity : 50mS/m (500μS/cm) above
 Flow velocity : 0.01 to 0.2m/s
 Coexisting components : Not containing large amounts of calcium, aluminum, iron, etc....Note 3

Note 1:

At pH 4 or below, fluorine exists as HF molecules (non-ionized), so this monitor cannot detect it. At pH 9 or above, the influence of OH ions becomes significant, causing higher readings. Furthermore, large pH fluctuations can alter the state of fluorine compounds, potentially releasing fluoride ions or conversely transforming them into compounds that cannot be detected. Therefore, we recommend using this monitor in locations where pH fluctuations are minimal.

Note 2:

Fluorine present as precipitates such as calcium fluoride may partially dissolve due to changes in sample water temperature, converting to fluoride ions and causing changes in the measured value. This can pose management issues. Therefore, we recommend conducting measurements at a constant temperature below 40°C whenever possible.

Note 3:

Elements such as calcium, aluminum, and iron form compounds with fluorine that differ from fluoride ions. Since this monitor cannot detect such compounds, it will show lower values compared to the JIS method (which involves distillation processing to measure total fluorine by decomposing these compounds).

Measurement Principle

A fluoride ion electrode generates a constant electromotive force (EMF) proportional to the concentration of fluoride ions in solution. This relationship is represented by the graph shown on the right, where the electrode's EMF exhibits a linear relationship with the logarithm of the fluoride ion concentration.

By pre-calibrating the instrument using a standard solution, the fluoride ion concentration can be measured simply by immersing the sensor in the sample.

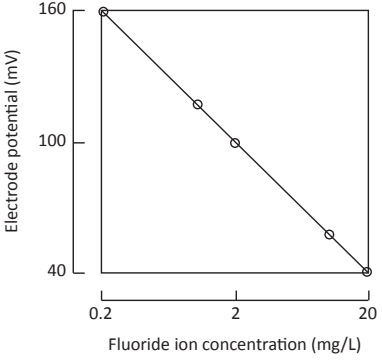

● Relationship between fluoride ion concentration and electrode electromotive force

Wiring Diagram

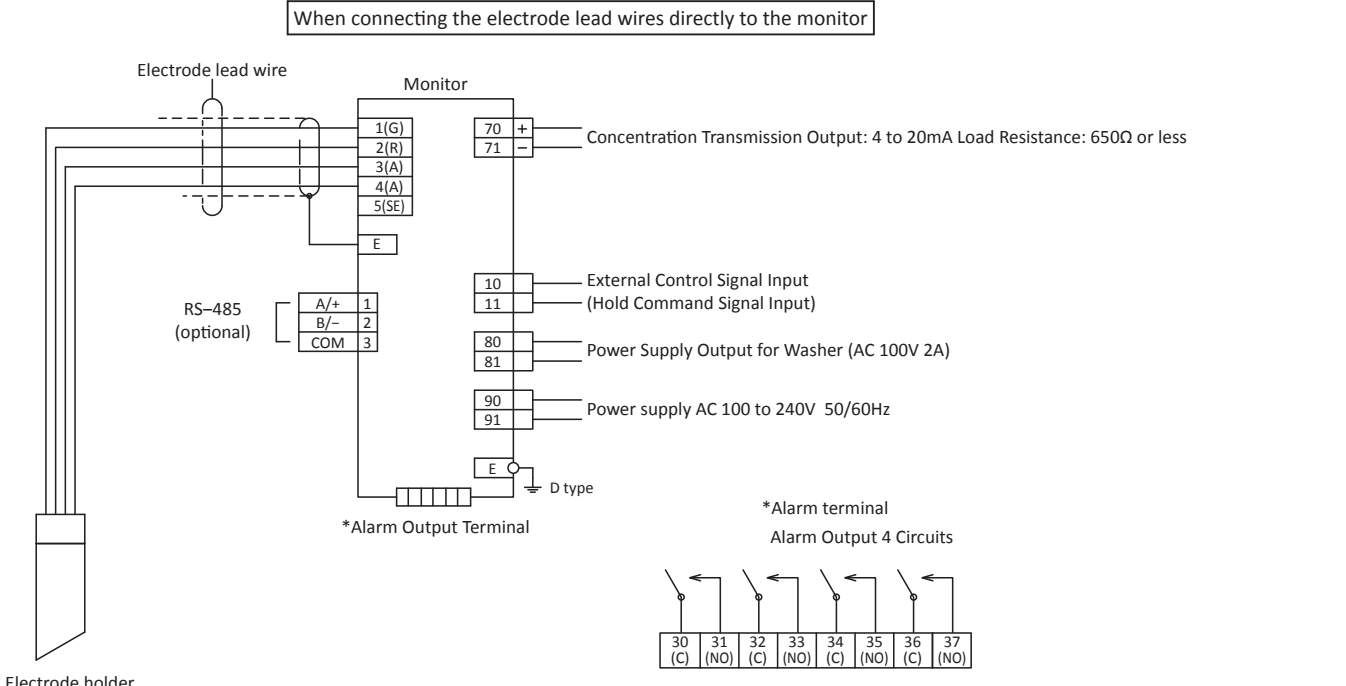
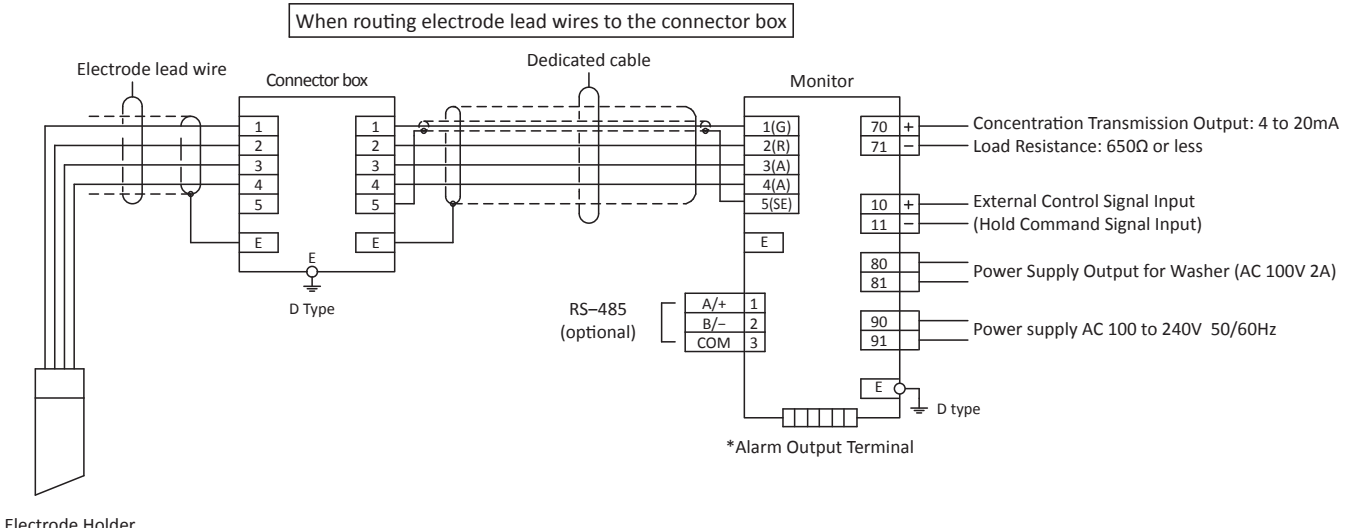

Contact Rating: AC 250V 3A (resistive load) or DC 30V 3A (resistive load)
 Contact Output Function: Alarm output contacts for upper limit alarm, lower limit alarm, and cleaning in progress signal
 Switchable between maintenance signal and fault signal

Dimensions

Unit : mm

● FBM-100B Panel installation

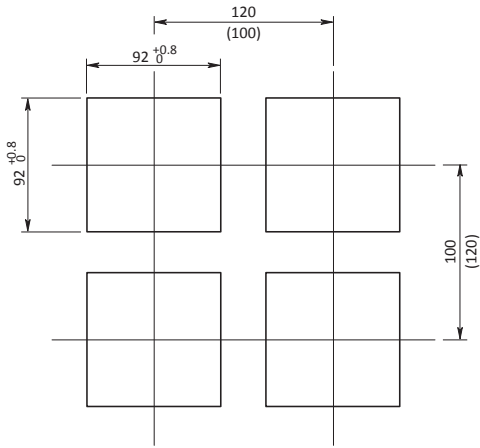

Panel Cutting Dimension Drawing

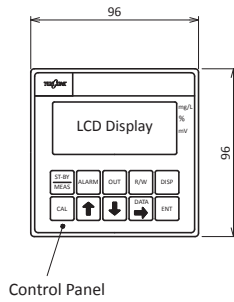

Control Panel

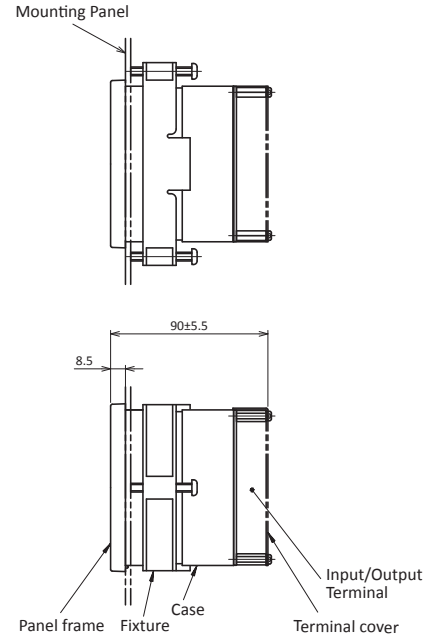

Panel frame Fixture Case Input/Output Terminal Terminal cover

Display Panel

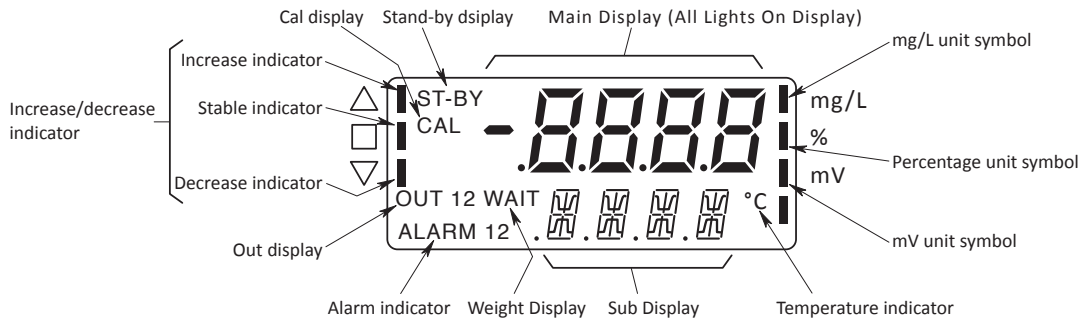

Product code

FBM100B-0-□□	Transmission Output (DC 4 to 20 mA) Range
A	0 to 20.0 mg/L (Measurement display range: 0.0 to 99.9 mg/L)
B	0 to 200 mg/L (Measurement display range: 0 to 999 mg/L)
C	0 to 2000 mg/L (Measurement display range: 0 to 9990 mg/L)
Y	Other specifications*1
0	Digital Output RS-485 (Modbus) None
1	Equipped
A	Notation Form Standard
B	English

*1. For "Other Specifications," please notify us of the measurement display range for each of the three types, which must be at least 1/10 FS.

<Example> 0 to 10 mg/L 0 to 50 mg/L
0 to 100 mg/L 0 to 5000 mg/L

■ Combination detector

Electrode Structure and Specification

The electrode consists of an electrode body, which integrates the epoxy resin material and fluoropolymer liquid junction, and a replaceable tip that integrates the sensing membrane (lanthanum fluoride) and body (epoxy resin material). It also features a polyethylene protective sleeve. When the sensing membrane's performance declines, the tip can be easily replaced.

Model	ELCP-81-□F
Sensitive membrane	Lanthanum fluoride
Measurement range	0.1 to 10,000 mg/LF ⁻
Temperature resistance range	-10 to 50°C
Operation temperature range	-5 to 40°C
Operating pressure range	0 to 0.2 MPa
Internal electrode	Silver/silver chloride electrode
Comparative internal fluid	Gelatinous KCl (non-replenishable)
Wetted parts material	Epoxy resin, PTFE resin, fluorinated rubber, Delrin
Replacement tip	EL7208L

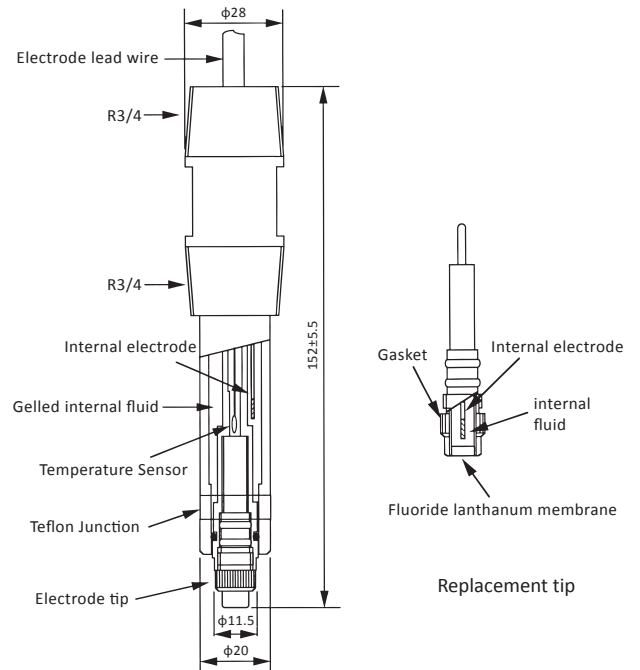

Electrode Holder Outline Drawing

Unit : mm

● Immersion type HC-D70C / D76 (Resin)

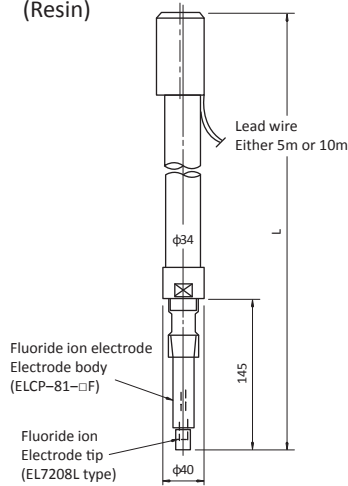

● Immersion Type with Water Jet Cleaning JHCP-7E

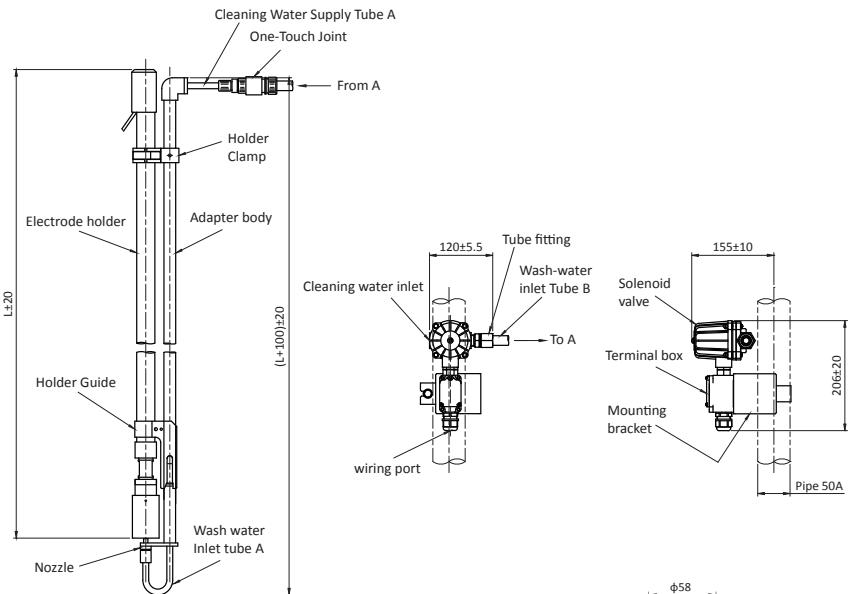

● Liquid-type HC-D82 (SUS316 construction)

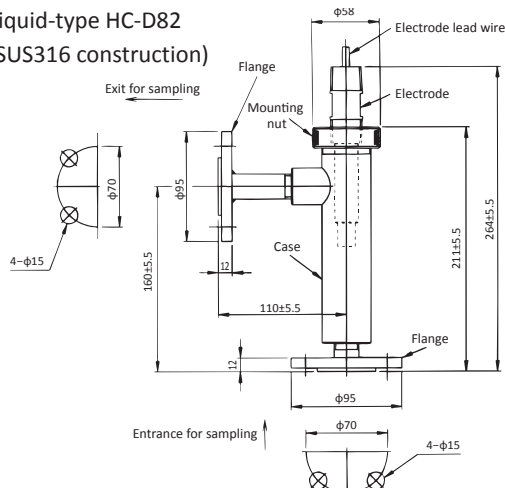

● Liquid-flow Type HC-D86 (Resin)

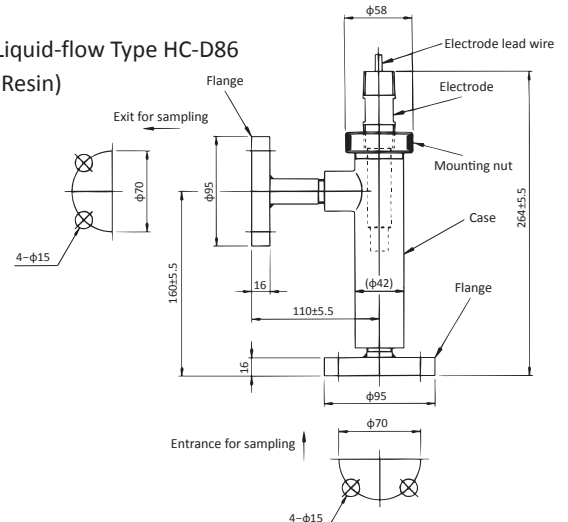

Electrode Holder Product Code

<Immersion type>

HC-D70C Type (Material: PVC)

HC-D70F Type (Material: PVDF)

HC-D76 Type (Material: PP)

HCD70C-3-	□□□□□□□□	
HCD70F-3-	□□□□□□□□	
HCD76 -3-	□□□□□□□□	
		Holder length*1
1	0.5m
2	1.0m
3	1.5m
4	2.0m
5	2.5m
6	3.0m
9	Special
		Embedded electrode
0	None
G	Fluoride Ion ELCP-81★
		Length of electrode lead wire
0	When no electrodes are required
K	5m (Holder length 2m or less)
M	10m
Y	Other Designations
		Holder Guide Assy*2
A	Not Included
B	JHCP-7E, RHCP-7E
G	General use
		Protective Sleeve*3
Special specification code	0	None (for general use)
Number of digits: 9	2	JHCP-7E, RHCP-7E
Alphanumeric digits: Z		Marking
	0	Standard
	1	English
	0	Individual inspection
	0	None

★ Not certified

*1. The HC-D76 holder length is limited to 3m (due to significant deflection).

*2. Required when combining with the ZN-7 indicator bracket.

*3. Always select the holder guide assembly and protective tube designed for the same washing device.

Note 1. The holder temperature range is as follows. However, ensure it does not exceed the maximum temperature of the embedded electrode.

Model	Temperature range
HC-D70C	-5 to 60°C
HC-D70F	-5 to 95°C
HC-D76	-5 to 80°C

Model	Replacement Tip Model	Temperature range
ELCP-81	7208L	-5 to 40°C

<Calibration standard solution>

· Ion Strength Adjusting Agent Standard Solution

(Use it as is for calibration. Diluting it will prevent you from obtain the correct value.)

- Fluoride Ion Standard Solution F⁻ 2mg/L 500mL (Code No.6507970K)
- Fluoride Ion Standard Solution F⁻ 20mg/L 500mL (Code No.6507980K)
- Fluoride Ion Standard Solution F⁻ 200mg/L 500mL (Code No.6511190K)
- Fluoride Ion Standard Solution F⁻ 2000mg/L 500mL (Code No.6511200K)
- Fluoride Ion Standard Solution F⁻ 3000mg/L 500mL (Code No.6511220K)

<Concentrate for Calibration Fluid Adjustment>

(Follow the instruction manual to add the ion strength adjuster to the fluoride ion standard solution, then dilute with water to prepare the calibration solution at the specified concentration.)

- Fluoride Ion Standard Solution F⁻ 1000mg/L 500mL (Code No.143F077)
- Ion Strength Modifier pH5-AB 500mL (Code No.143A053)

HC-D82 Type (SUS316 Flowing liquid type)

HCD82-0-	□□	
		Connection size (specification)
1	Rc ¹ / ₂
2	15A JIS10K RF
3	25A JIS10K RF
9	Special
		Marking
A	Standard
B	English
Z	Special

Combination electrodes require separate arrangement.

ELCP81-0-□F Operating pressure: 0 to 0.2 MPa

HC-D86 Type (Resin-based flowable type)

HCD86-1-	□□□	
		Material
1	Polypropylene (PP)
2	PVC
9	Special
		Connection size (specification)
1	Rc ¹ / ₂
2	15A JIS10K FF
3	25A JIS10K FF
9	Special
		Marking
A	Standard
B	English
Z	Special

Combination electrodes require separate arrangement.

ELCP81-0-□F Operating pressure: 0 to 0.15 MPa

JHCP-7E Type (Immersion Detector with Water Jet Cleaning)

JHCP7E-3-	□□□□□□□□	
		Power *1
A	AC 100V 50/60Hz
		Wetted materials in the cleaning section
1	SUS316(Standard)
2	SUS316L
		Combination Holder (No separate required)*2
0	No holder is required
1	PP Holder HC-D76
2	Transparent PVC holder HC-D70C
		Combination Holder Length*3
1	0.5m ↑The total length of
2	1.0m the detector is determined.
3	1.5m
4	2.0m
5	2.5m
6	3.0m
		Embedded electrode
0	None
G	Fluoride Ion ELCP-81★
		Electrode lead wire length*2
0	When no electrodes are required
K	5m (Holder length 2m or less)
M	10m
Y	Other specification
		Marking
Special specification code	0	Standard
Number of digits: 9	1	English
Alphanumeric digits: Z		Individual inspection
	0	None

★ Not certified

*. This is the power supply supplied to the detector via the FBM-type monitor.

For power supplies of 100V AC or higher, a step-down transformer (ZP: 35VA) is required between the FBM type and the detector. (Separately attached)

Installation Diagram

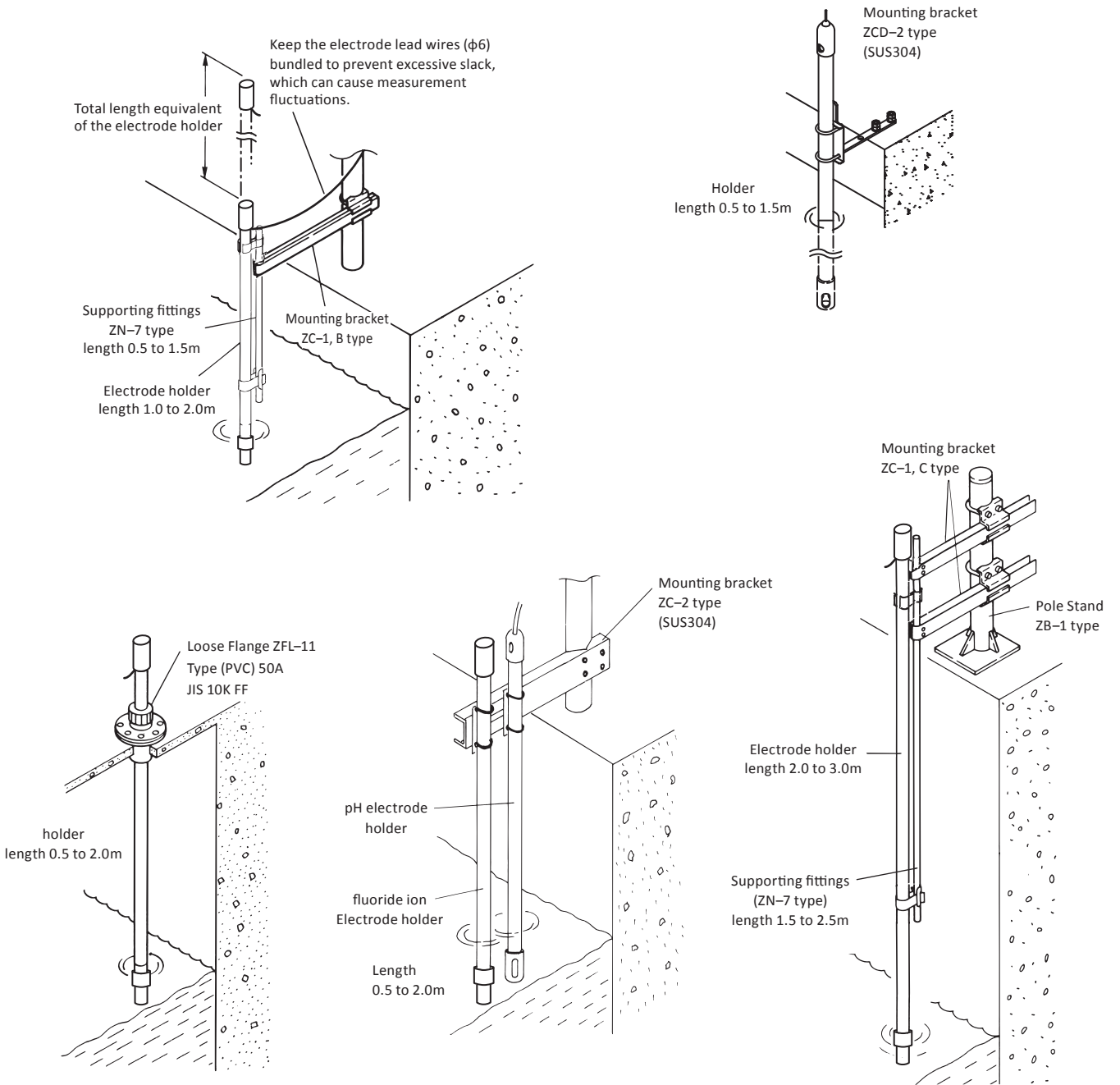



DKK-TOA CORPORATION

Overseas Sales Division:
DKK-TOA Corporation
29-10, 1-Chome, Takadanobaba, Shinjuku-ku,
Tokyo 169-8648 Japan
Tel : +81-3-3202-0225 Fax : +81-3-3202-5685
E-mail : intsales@dkktoa.com



CAUTION

Please read the operation manual carefully
before using products.

<https://www.toadkk.com/english/>

Information and specifications are subject to change without notice.