

OIL FILM DETECTOR
(Long-distance correspondence Version)

ODL-1610A

The Model ODL-1600A monitors a water surface for the presence of an oil film floating on the surface. The instrument projects a laser beam onto the water surface and measures the differences in the reflection properties between water and oil.

The ODL-1610A is an enhanced version of the existing oil-on-water monitor model ODL-1600, a device which is specially designed for long distance detection. While this model inherits the proven technology employed in the existing model, such as laser scanning and high-speed pulsing, it also comes with a larger condensing mirror and other new enhancements. The addition of this larger mirror allows the detector to be installed as high as 10m above the surface of the water.



Features

Non contact detection system.

Scanning laser beam system provides enhanced detection even under difficult surface conditions such as the presence of floating debris, bubbles or curved oil surfaces.

The laser scanning system does not contain any rotating or sliding parts. In place of these parts, the system comes with a scanning mirror that is actuated by resonant oscillation produced by two reliable piezoelectric elements (bimorph elements) attached to the mirror. This structure eliminates the need for disposable parts used in laser scanning, thus providing greater durability and reliability during non-stop operation.

The ODL-1610 is equipped with a built-in micro-computer that can configure and store multiple operating parameters. This provides greater flexibility for conducting operations in a variety of sensing environments. In addition, the device also comes with a number of useful functions for support maintenance operations, such as monitoring the sensitivity of the light sensor to reflected light, storing oil-on-water and abnormal alarm history data, and comprehensive self-diagnostics.

The instrument is also capable of detecting leakage of water or oil on dry surfaces.

The enhanced optical design allows the detector to be installed at heights of 0.3 to 10 m above the surface of the water. (See the Installation Conditions section for details.)

This extensive range enables you to install the detector in locations where the water level fluctuates greatly or where it is difficult to come close to the surface of the water.

Simple, easy to adjust mounting brackets allow easy installation and maintenance.

A single transmitter can control up to two detectors (optional).

Specifications

<p>Product Name : Oil Film Detector (Long-distance correspondence Version)</p> <p>Model Code : ODL-1610A</p> <p>Measurement : Oil slick floating on water surface or dry Object surface (floor)</p> <p>Measurement : Reflectance of visible light</p> <p>Method</p> <p>Sensor Distance : 0.3m - 10m above water or floor surface</p> <p>Light Source : Class 2 semiconductor laser diode (red)</p> <p>Configuration : Detector and transmitter housed in separate enclosures.</p> <p>Ingress Protection : Dust proof and jet-water resistant IP65</p> <p>Ambient Conditions : Temperature ; -10 - 50°C Humidity ; 5 - 95%RH</p> <p>Sample Temperature : No freezing</p> <p>Transmission output signals : 4 - 20mADC (maximum load resistance of 600Ω), isolated</p> <p>A transmitter can be used to specify one of the following modes for analog output:</p> <p>①Standard output mode Normal conditions; Approximately 10.4mA (still water) Oil film present; Approximately 13.6mA or more Undetectable conditions; Approximately 4mA (no reflectance)</p> <p>②ODL-20 compatibility mode Normal conditions; 18mA (fixed value) Oil film present; 20mA (fixed value) Undetectable conditions; 16mA (fixed value)</p> <p>The burnout alarm function can be used in mode①</p> <p>When oil-on-water alarm is ON; 21mA (fixed value)</p> <p>When undetectable alarm is ON; 3mA (fixed value)</p> <p>(Abnormal alarm conditions include both measurement errors and instrument malfunctions.)</p>	<p>Alarm contact output signals : Total of 6 available alarm contacts (5 for "a" or "b" contacts*1, 1 for "c" contact) *1; Specify "a" or "b" when placing an order. Contact capacity; 240VAC, 1A or 30VDC, 1A (resistance load) The following alarm contact outputs can be freely assigned; ①power-off, ②maintenance, ③oil-on-water alarm, ④measurement error, and ⑤instrument error. The same output can be selected in duplicate. However, contact output 1 is fixed for the power-off signal.</p> <p>Digital Communication System : - Based on RS-485 (isolated) - Available Baud rates ; 2400, 4800, 9600, 19200, 38400, 57600 - Protocol ; Modbus / RTU - Data length ; 8 bits - Parity ; select from NONE, ODD, EVEN - Stop bits ; 1 Bit - Data Order ; BIG ENDIAN</p> <p>Operating Power : 100 - 240VAC+/-10%, 50/60Hz Power Consumption : Approximately 13VA (maximum of 18VA) when at 100V Approximately 27VA (maximum of 32VA) when at 240V (When optional heater is installed consumption will be approx. 38VA.)</p> <p>Weight : - Transmitter ; approx. 2.2 kg - Detector section ; approx. 26 kg</p> <p>External Dimensions : - Transmitter ; approx. 181(W)x180(H)x95(D) (mm) - Detector ; approx. 307(diameter)x577(L) (mm)</p> <p>Construction : Transmitter ; die cast aluminium Materials Detector ; die cast aluminium</p> <p>Surface Finish : Metallic silver</p> <p>Electrical Connections : - Transmitter ; 6 cable glands for 6 - 12mm diameter cable, G1/2 threaded connections when gland removed. - Detector ; 1 cable glands for 6 - 12mm diameter cable, G1/2 threaded connections when gland removed. 3 spare electrical connections (G1/2 stop plug)</p> <p>Connecting Cable Lengths : - Transmitter to detector ; max 100m (power and communication cable) - Transmitter to receiving device ; max 100m (digital communication)</p>
--	---

Principle of Operation

The reflectance of light from an oil film is greater than that of water. When an oil film is present on a water surface, it generates a "glistening" effect. From this property, the presence of oil can be detected by applying a light beam of constant intensity to the water surface and then measuring the intensity of the reflected light.

The detector contains a semiconductor laser diode, a laser scanner, reflecting mirror and a photodiode light sensor. The light output from the laser tube is scanned across the water surface periodically across the x-y axis.

The light that is reflected back by the water surface is captured by a parabolic mirror and focused on to a sensor located at the focal point of the mirror. The signal from the light sensor is processed by the micro electronics in the transmitter. From the processed signal it can be determined whether an oil film is present or not. The transmitter provides output signals indicating the detection status such as contact switching signals, analogue signals etc..

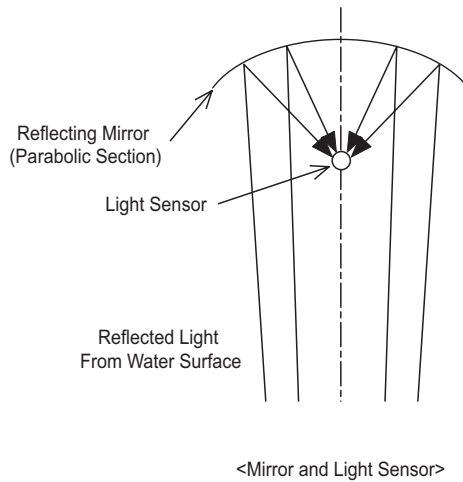
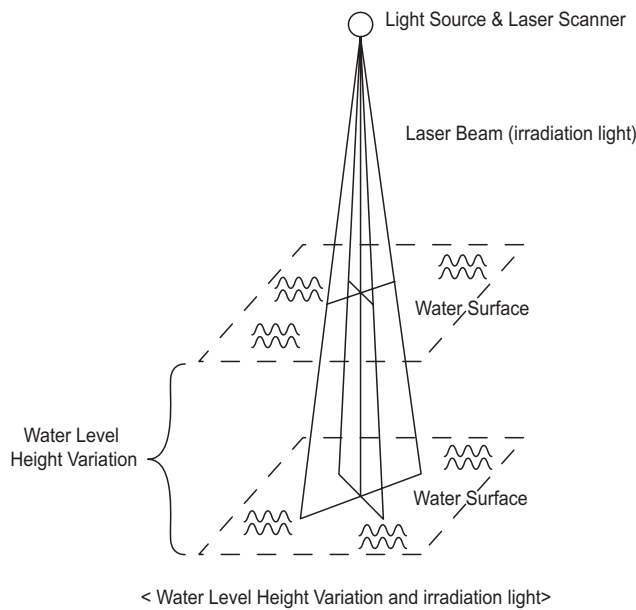

Light receiving of the borrowed light

System Configuration

The instrument comprises a detector and transmitter. The detector and transmitter continuously communicate. The raw detection signal, reflected light intensity data and diagnostic information are sent from the detector to the transmitter.

The transmitter displays information about the status. It also generates analog and alarm contact output signals to transmit this information to external devices.

The operating-parameter settings specified on the transmitter are also applied to the detector.

When a single transmitter is shared by 2 detectors, the transmitter communicates with each detector separately. It also provides individual analog and alarm contact output signals for each detector (maximum of 6 contacts). These signals are used to transmit instrument data.

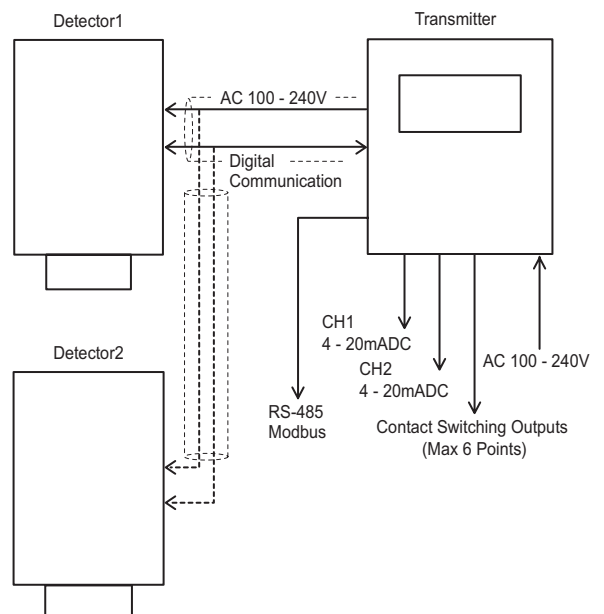

Transmitter Functions

(1) Display

The transmitter displays information on calibration, oil film detection status, raw light intensity, selfdiagnostics and error conditions.

(2) Oil Detection Modes

The transmitter allows the detector to be set up for particular water surface conditions such as still, smooth surfaces or unstable surfaces with waves and bubbles etc.. The transmitter allows the operator to establish a suitable set up for the particular installation conditions.

(3) Analogue Output Signals

The reflection light intensity detected from water surface is output to 4 - 20mA of analogue signal seale. By utilizing burn-out function built in transmitter, oil alarm and abnormal signal can be output at the out of the scale range such as 21mA and 3mA. It is possible to transmit the signal of occurrence of alarm and abnormal on the top of detecting condition status under normal operation through one analogue output line.

(4) Contact Switching Output Signals

A total of 6 contact switching signal are available.

The transmitter can generate a total of 6 alarm contact output signals.

The available signals are as follows : - Oil film detection.

- Under maintenance (ST-BY mode).

- Detection error (water surface detection error, reflected light error, ambient light error).

- Instrument malfunction (laser output trouble, internal temperature alarm).

- Power failure (open or closed contact available).

(5) External Device Communication

Digital communication with external devices is available using Modbus protocol from the RS485 output signal.

(6) Optional Dual Detector Capability

It is possible to connect two detectors to a single transmitter enabling the monitoring of 2 different locations simultaneously.

(7) Detection History Stored in Memory

Up to 10 items of oil-on-water alarm history (ALM LOG) and 10 items of abnormal alarm history (ERR LOG) can be stored in memory. The detection parameters (the number of high peaks within a fixed period and the peak value of duration) are stored separately in the memory with the data and time of detection as oil-on-water detection history, even when the oil-on-water alarm is not activated. This data can be re-called by the operator. The history data can provides useful information for fine-tuning the sensitivity settings for oil film detection and other detection modes.

Terminal Connections

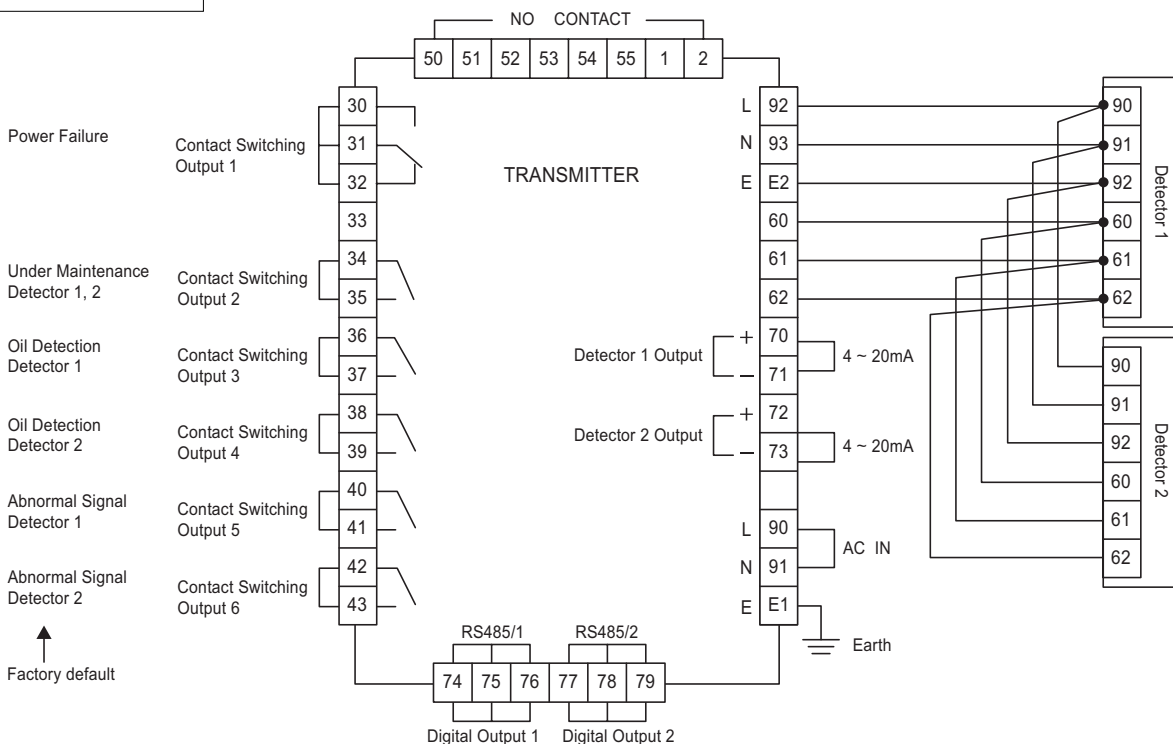

Dimensions Unit : mm

● **Transmitter**

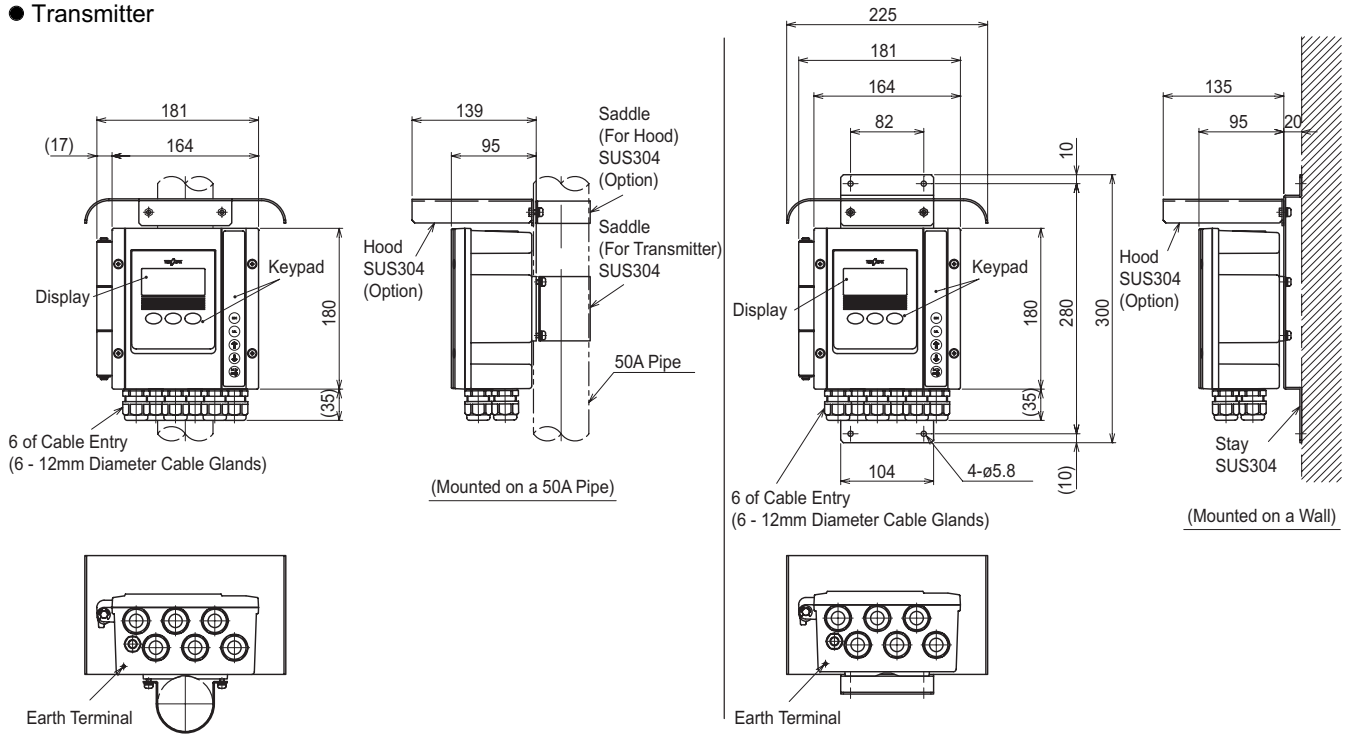

● **Detector**

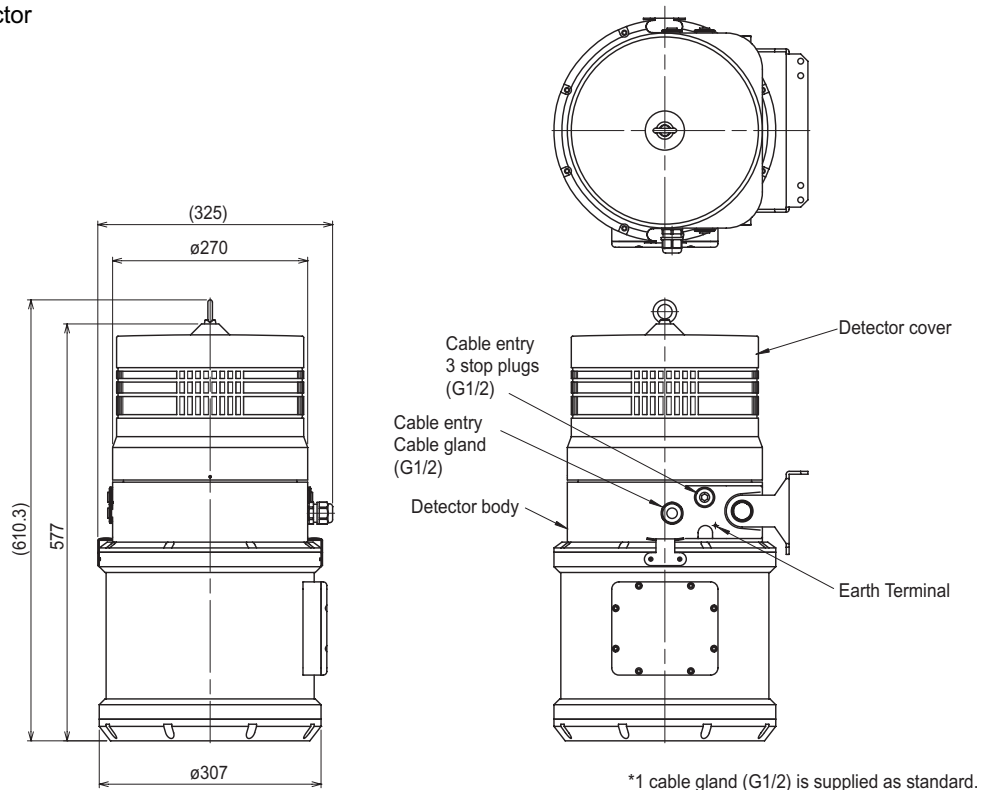

Installation

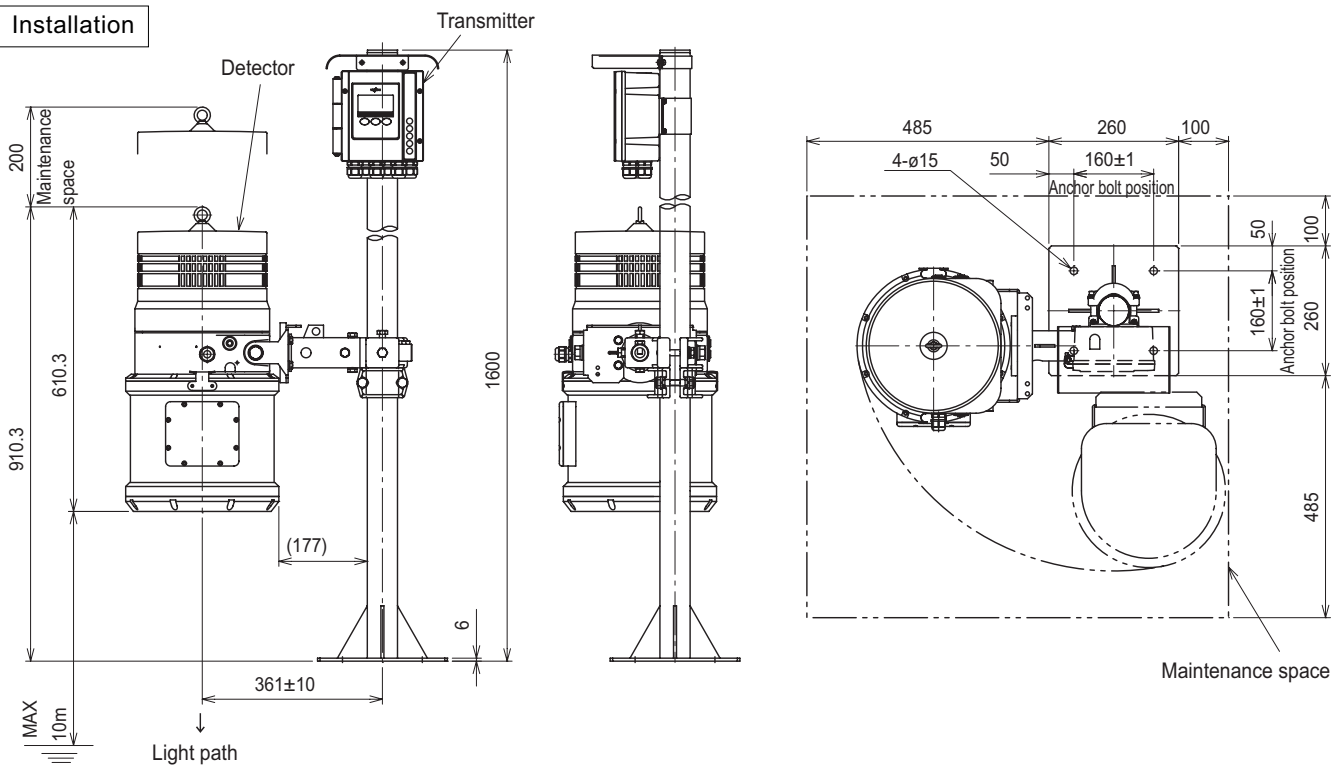

Installation Conditions

1. Ideally, the device should be placed as close as possible to the surface of the water. However, do not place the detector with less than 0.3m of the surface. A sufficient amount of distance between the detector and the surface of the water must be maintained to protect the detector window on the bottom from being hit by splashes of water during heavy rain. In addition, make sure to consider potential fluctuations in the water level when selecting an installation location. The sensor distance must always lie within the specified range (0.3 - 10 m).
2. Install the analyzer at a location where the water flows smoothly. Avoid locations where there is turbulence.
3. Install the analyzer at the location where the monitoring surface will not be subjected to direct rainfall or direct wind disturbance, because a severely rippled water surface may make it difficult for oil film detection. For such locations, protection against direct rainfall or wind disturbance will be required.
4. Avoid installing the detector in locations where dead leaves or other debris may accumulate on the water surface. These may affect water flow characteristics and cause detection problems.
5. Install the detector at the place where the surveillance water surface area is not exposed to direct sun light. There is possibility that it generates abnormal signal by reflection of sun light. Shade direct sun light with cover and etc. in such case.
6. It is recommended to use optional sun shade at the place where is high ambient temperature and exposed with direct sun light.
7. Install the instrument in a location where vibrations and mechanical shocks are minimised. Secure a space around the analyzer and scaffolding if necessary for a safe and easy access during maintenance.
8. Avoid locations where there is rising mist due to high water temperature. If this is unavoidable, supplying a gentle airflow will effectively clear the vapour away.
9. If using the instrument to monitor liquid leakage on dry surfaces (such as floors etc.), ensure that the surface is horizontal. A sloping surface will not reflect the light from the laser beam correctly and cause detection problems. Select a part of the surface where any leaked liquid will form a smooth liquid film. If the dry surface is excessively shiny, place a non-reflective surface over it such as a black rubber mat etc..
10. In case that the main power supply fluctuates by large-capacity power apparatuses greatly, we recommend installing the relay with the timer in the socket of the point of contact output.

Note: Water surface conditions

When conducting optical measurements, ripples on the surface of the water surface can cause light to scatter. As a result, the intensity of the reflected light will fail to reach 100% of its normal intensity level. This is especially true when there is a significant amount of distance between the sensor and the surface of the water. We recommend you to take adequate measures to avoid this problem.

Product code

ODL1610A-0-□□□□□□□□□□									
1	Transmitter Mounting							
2	On a 50A pole							
1	Wall or rack mounting							
2	Surface finish (coating)*1							
1	Standard coating							
2	Heavy duty coating (in case of 1 detector)							
3	Heavy duty coating (in case of 2 detectors)							
0	Arrester (power line/transmission line) *2							
0	None							
1	Included							
A	Cable entry for power, transmission and signal cable*3							
B	Cable glands for ø6 - 12 cable (standard)							
C	Cable glands (G1/2 conduit threads when the cable glands are detached)							
	NPT 1/2 supplied with 6 adapters							
	Number of Detectors Connected							
1	1 (Detector 1; GODL-161U)							
2	2 (Detector 1; GODL-161U, and Detector 2; GODL-161U)							
8	2 (Others)							
	Cable Length from Transmitter to Detector *4							
1	2m (standard)							
2	10m							
3	20m							
4	100m							
8	Custom specification (max 100m)							
	Cable Length from Detector1 to Detector2 *4							
0	None (in case of 1 detector)							
1	2m							
2	10m							
3	20m							
4	98m							
8	Custom specification (max 98m)							
	Alarm contact output (contact output2 - 6)*5							
A	a contact (240VAC 1A or 30VDC 1A)							
B	b contact (240VAC 1A or 30VDC 1A)							
	Anti Misting Heater for Detector Glass *6							
0	None							
1	Equipped to Detector1 only							
2	Equipped to Detector2 only							
3	Equipped to both Detectors1 and 2							
	Mounting Bracket for Detector1							
1	For Mounting on 50A pole (Pole available as an option)							
2	For Replacement of ODL-12 *7							
3	For Replacement of ODL-20 *7							
4	For Replacement for others *7							
9	Special *7							
	Mounting Bracket for Detector2							
0	None (in case of 1 detector)							
1	For mounting on 50A pole (pole available as an option)							
2	For Replacement of ODL-12 *7							
3	For Replacement of ODL-20 *7							
4	For Replacement for others *7							
9	Special *7							
	Sun Shade							
0	None							
1	Equipped to Transmitter Only							
	Markings							
A	Japanese Language (Standard)							
B	English Language							

Custom spec. code;
 Numeric digit: 9
 Alphabet: Z

- *1. Melamine resin is applied to primer coat and finish coat for the standard painting.
 The average thickness of film of paint is 30µ or more and the glossiness is G40.
 Melamine resin is applied to primer coat and middle coat and polyurethane resin is applied to finish coat for heavy-duty coating. The average thickness of film of paint is 100µ or more and the glossiness is G80.
- *2. The ceramic surge arrester (simplified) is mounted on the power line and transmission line.
- *3. There are 6 cable ports which are mounted with ø6 - 12 of cable glands. When cable gland is removed, G1/2 of conduit threads of the entry port is appeared. When NPT1/2 of cable port is requested, as 6 adaptors (SUS-316) shall be supplied, replace the necessary number of the cable glands with adaptors from the ports. If some ports are not used for conduit, please leave the cable glands for sealing.
- *4. The maximum total cable length between transmitter, detector1 and detector2 is 100m (i.e. if cable length from detector1 to detector2 is 98m then max cable length from transmitter to detector1 is 2m. Cable lengths are specified in 1m increments. Detector2 must connect to terminals of Detector1. Detector2 should not connect directly to the Transmitter.
- *5. There are 6 available alarm contact output signals. Contact output1 is set to power cut-off signal. Contact outputs2 to 6 can be configured by the operator to indicate oil-on-water alarms, maintenance, abnormal alarms, and other items. The only "c" contact is contact output1. However, the contact capacity of contact1 is the same as that of the other 5 contact outputs.

- The contact configuration ("a" contact or "b" contact) is specified at the factory. In principle, it cannot be changed after the device is shipped from the factory.
 When using the device in an environment in which machinery with a large-power capacity causes extreme fluctuations in the power supply, we recommend attaching a relay with a timer to the terminal for receiving contact output signals. This relay can help prevent false alarms.
- *6. An anti-misting heater for the detector glass (acrylic) is recommended. Select "equipped" if the installation location is prone to sudden temperature changes from low to high and/or the location is subject to high humidity. For example a heater would be required if the temperature changes from 10°C to 25°C within 30 minutes and ambient humidity is 90%.
- 7. If replacing existing Model ODL-12 or ODL-20 instruments, it is necessary to check types of existing fitting brackets and also analogue and alarm signals. Changes may be required to accommodate the new instrument - please consult with your local sales office or distributor.

- Notes :
- 1. The instrument operates on multi-voltage supply of 100 to 240VAC.
 - 2. Analogue output is 4 - 20mA.
 - 3. Order B-150 or ZB-1 if a mounting pole is required.
 - 4. The construction of the transmitter and detector are rated IP65. If you plan to use the detector in an environment in which it might become submerged in water, please contact one of our sales representatives.

Dimensions

Unit : mm

● Mounting Bracket

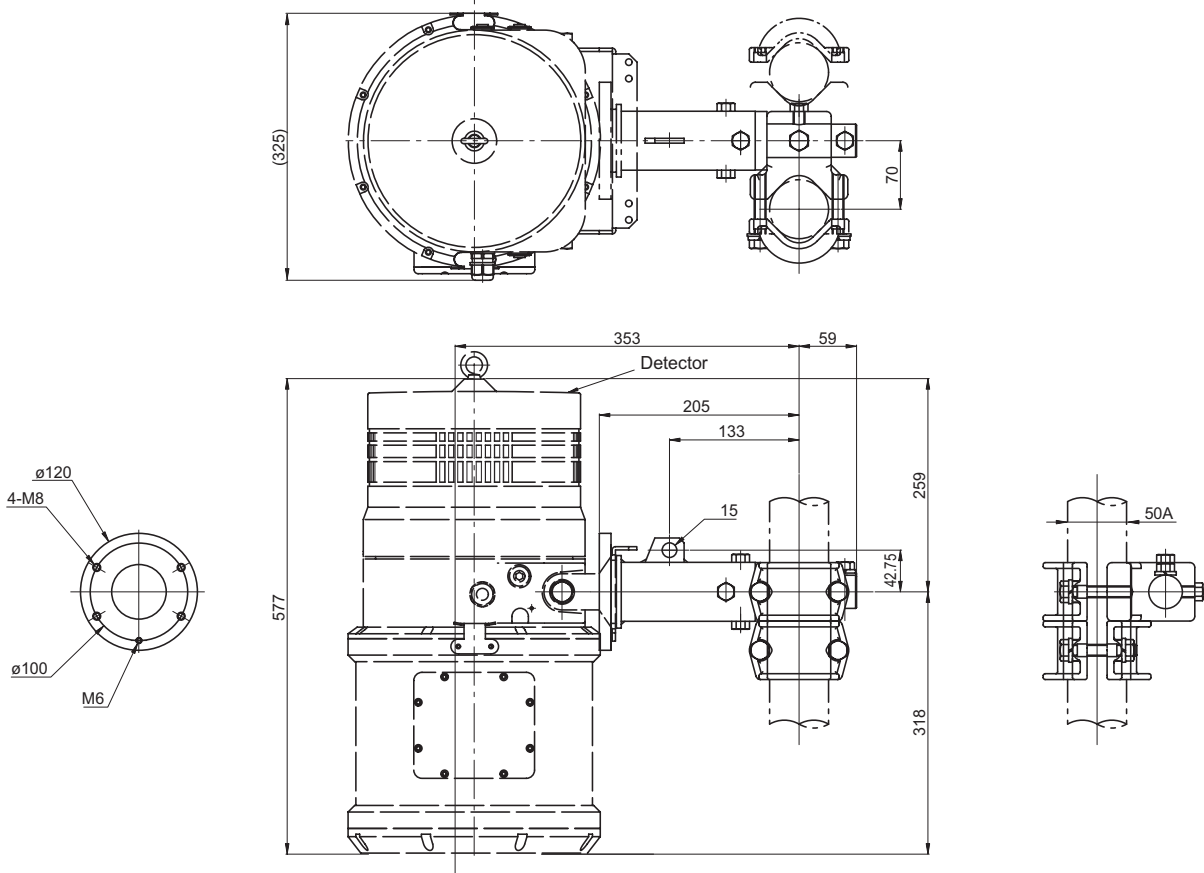

DKK-TOA CORPORATION

International Operations:
DKK-TOA Corporation
29-10, 1-Chome, Takadanobaba, Shinjuku-ku,
Tokyo 169-8648 Japan
Tel : +81-3-3202-0225 Fax : +81-3-3202-5685



CAUTION

Do not operate products before consulting instruction manual.