

NITROGEN OXIDES ANALYZER

GLN-390

USEPA Designation No. RFNA-0508-171

This is a nitrogen oxide (NO_x) analyzer in ambient air that adopts the chemical luminescence method. The flow path switching method measures nitrogen oxide (NO) and NO_x alternately to ensure stable measurement of a small amount of NO in the atmosphere.



Characteristics

- Adopts PMT on detector that directly cools cathodes. It reduces noise, compared to the old model.
- A detection unit increases maintainability and reduces maintenance cost, having a structure that can maintain such components as cooling elements, PMT and reaction cells individually.
- A dust filter is mounted on the panel on the front surface of the analyzer to facilitate dirt checking and filter replacement.
- The optional Ethernet interface unit enables data collection and remote control via LAN.
- The optional CF card records measurements recorded by an analyzer (instantaneous values and hourly average values), the status within an analyzer (temperature, pressure and flow rate), and history of zero deviations, span coefficients, alarms and events.* Data is kept as CSV files in the CF card to facilitate data editing. Various types of data (e.g. minute values, hourly values, alarms and events) are classified into year- or month-wise groups for convenient data organizing.
- A CF card can record the following data volume (the device only accepts our official CF cards that are to be used exclusively for the device.
Example of storable data (256 MB): data for about 8 years (regular recording only)
- The temperature is controlled with high precision for key components including detector, measurement cell and heater block. This helps reduce the effects of changes in ambient temperature.

Standard specifications

Product name	: Nitrogen Oxides Analyzer
Model	: GLN-390
Measurement object	: NO ₂ , NO and NO _x
Measurement method	: Continuous measurement by the chemical luminescence method (User selectable)
Meas. range	: 0 to 0.1 / 0.2 / 0.5 / 1.0 / 2.0ppm (Optional: 0 to 0.05 ppm or 0 to 20ppm)
Unit	: ppm, ppb, mg/m ³ , µg/m ³ (selectable)
Analog Output Ranges	: 0 to 1V DC, 0 to 10V DC, 4 to 20mA (selectable)
Communication	: RS232C, Ethernet TCP/IP (option)
Linearity (indication error)	: Within ±1% FS
Repeatability	: Within ±1% FS
Minimum detection limit	: Within 0.5ppb
Zero noise	: Within 0.5ppb
Stability	: Zero drift; within ±0.2ppb/day, within ±4ppb/week Span drift; within ±1% FS/day, within ±2% FS/week
Converter efficiency	: 95% or more
Response time	: Within 3minutes (90% response)
Effects of interference components	: Effects of moisture; effects of about 2.5 vol% are within ±4%. Effects of ammonium are 4ppb or less.
Warm-up time	: Approx. 3hours
Ambient temperature/humidity	: 0 to 40°C, RH 85% or less
Power source	: 220V AC, 50/60Hz
Power consumption	: Approx. 250VA at maximum; Approx. 170W on average
Flow of sample in ambient air	: Approx. 1.2L/min. (20°C, 1atm)
Outside dimensions	: 399 (W) × 520 (D) × 216 (H) mm
Weight	: Approx. 19kg

Measurement system diagram

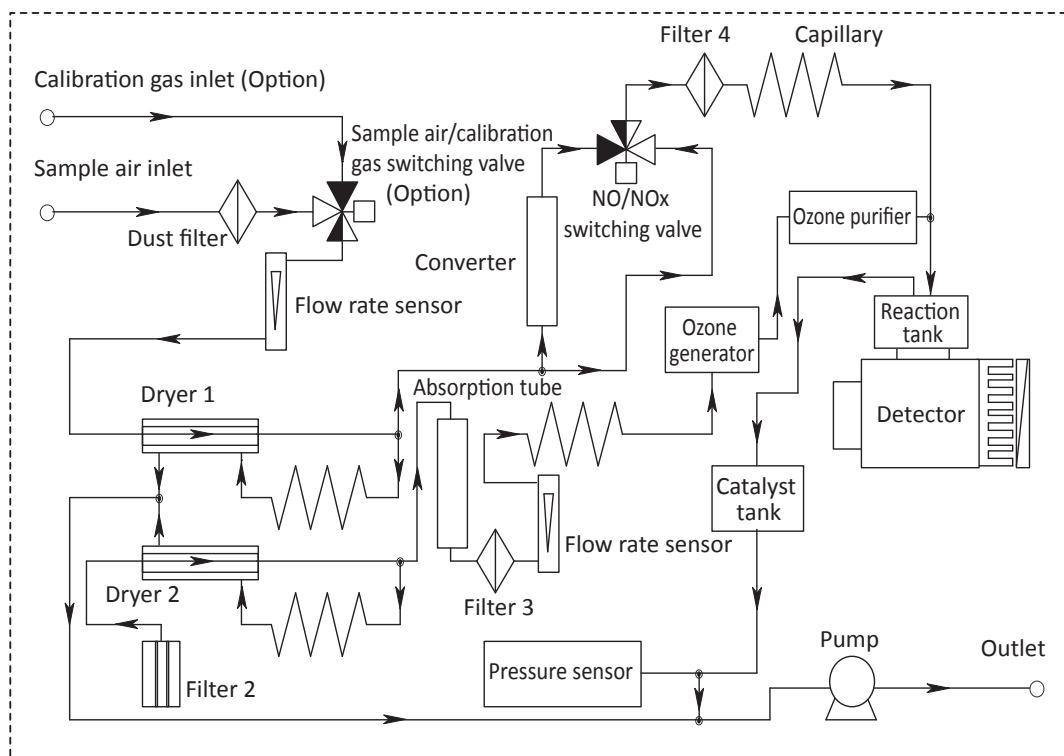

Dimensions

Unit : mm

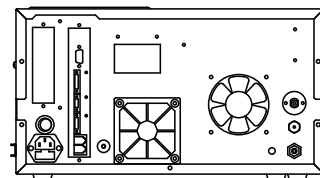
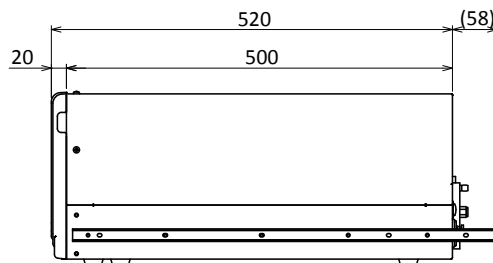
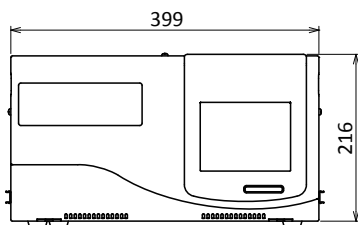

DKK-TOA CORPORATION

CAUTION

Please read the operation manual carefully before using products.

Overseas Sales Division:
 DKK-TOA Corporation
 29-10, 1-Chome, Takadanobaba, Shinjuku-ku,
 Tokyo 169-8648 Japan
 Tel : +81-3-3202-0225 Fax : +81-3-3202-5685
 E-mail : intsales@dkktoa.com



<https://www.toadkk.com/english/>

Information and specifications are subject to change without notice.