

CARBON MONOXIDE ANALYZER

GFC-390

USEPA Designation No. RFCA-0907-167

This is the carbon monoxide (CO) analyzer in ambient air that adopts gas filter correlation method. The device ensures stable measurement of a small amount of CO in the atmosphere because of the principle that avoids the effects of vibration and interference components.

The device has obtained model approval for densitometers under the Measurement Act.



Characteristics

- Adopts the gas filter correlation method for measurement. The method is almost free of the effects of interference components and optical stains.
- Uses multiple-reflection measuring cell to enable high-sensitivity measurement in the 5-ppm range.
- More resistant to vibration with the semiconductor infrared detector.
- Enables stable measurement with the original digital signal processing technology.
- The optional Ethernet interface unit enables data collection and remote control via LAN.
- The optional CF card records measurements recorded by an analyzer (instantaneous values and hourly average values), the status within an analyzer (temperature, pressure and flow rate), and history of zero deviations, span coefficients, alarms and events.* Data is kept as CSV files in the CF card to facilitate data editing. Various types of data (e.g. minute values, hourly values, alarms and events) are classified into year- or month-wise groups for convenient data organizing.
- A CF card can record the following data volume (the device only accepts our official CF cards that are to be used exclusively for the device.)
Example of storable data (256 MB): data for about 12 years (only usual recording)

Standard specifications

Product name	: Carbon Monoxide Analyzer
Model	: GFC-390
Measurement object	: CO in ambient air
Measurement method	: Gas filter correlation method
Meas. range	: 0 to 5 / 10 / 20 / 50 / 100ppm (User selectable)
Unit	: ppm, ppb, mg/m ³ (selectable)
Analog Output	: 0 to 1V DC, 0 to 10V DC, 4 to 20mA (selectable)
Ranges	: (selectable)
Communication	: RS232C, Ethernet TCP/IP (option)
Linearity	: Within ±1% FS (indication error)
Repeatability	: Within ±1% FS
Minimum detection limit	: 0.5% FS(0.05ppm) or less
Zero noise	: Within 0.5ppb
Stability	: Zero drift; within ±0.1ppm/day, within ±0.2ppm/week Span drift; within ±1% FS/day, within ±2% FS/week
Flow of sample in ambient air	: Approx. 1L/min
Response time	: Within 2minutes (90% response)
Effects of interference components	: Effects of moisture; ±0.3ppm or less Effects of CO ₂ ; ±0.3ppm or less
Warm-up time	: Approx. 3hours
Ambient temperature/humidity	: 0 to 40°C, RH 85% or less
Power source	: 220V AC, 50/60Hz
Power consumption	: 250VA at maximum; 110W on average
Flow of sample in ambient air	: Approx. 1.0L/min. (20°C, 1atm)
Outside dimensions	: 399 (W) × 520 (D) × 216 (H) mm without rubber legs
Weight	: Approx. 18kg

Measurement system diagram

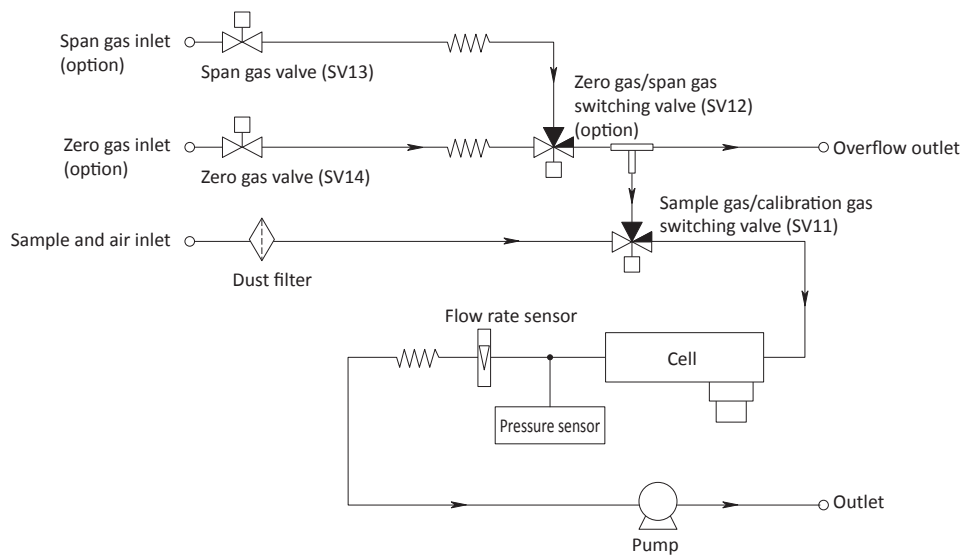

Dimensions

Unit : mm

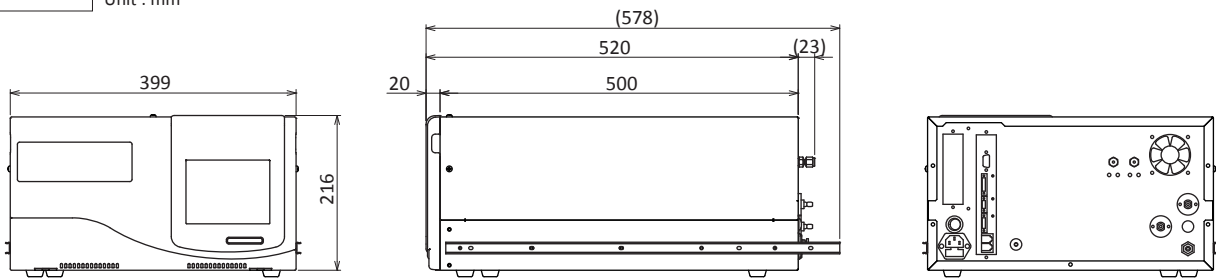

DKK-TOA CORPORATION

Overseas Sales Division:
 DKK-TOA Corporation
 29-10, 1-Chome, Takadanobaba, Shinjuku-ku,
 Tokyo 169-8648 Japan
 Tel : +81-3-3202-0225 Fax : +81-3-3202-5685
 E-mail : intsales@dkktoa.com



CAUTION

Please read the operation manual carefully before using products.